



## SECM599 Baureihe

### 5-Phasen-Schrittmotor mit Encoder [0,72° High-Torque-Version]

Model	Bipolar				Speed Torque
	Holding Torque [Nm]	Current / Phase [A]	Resistance / Phase [Ohm]	Inductance / Phase [mH]	
P = Line Drive 500 Counts/Turn SECM599-T2.8P2500	4.1	2.8	0.67	4.3	i

Number of Leads 10	Weight of Motor & Encoder 3.1 kg	Size Length 120.7 mm	Rotor Inertia 2000 x 10 <sup>-7</sup> kgm <sup>2</sup>
-----------------------	-------------------------------------	-------------------------	---

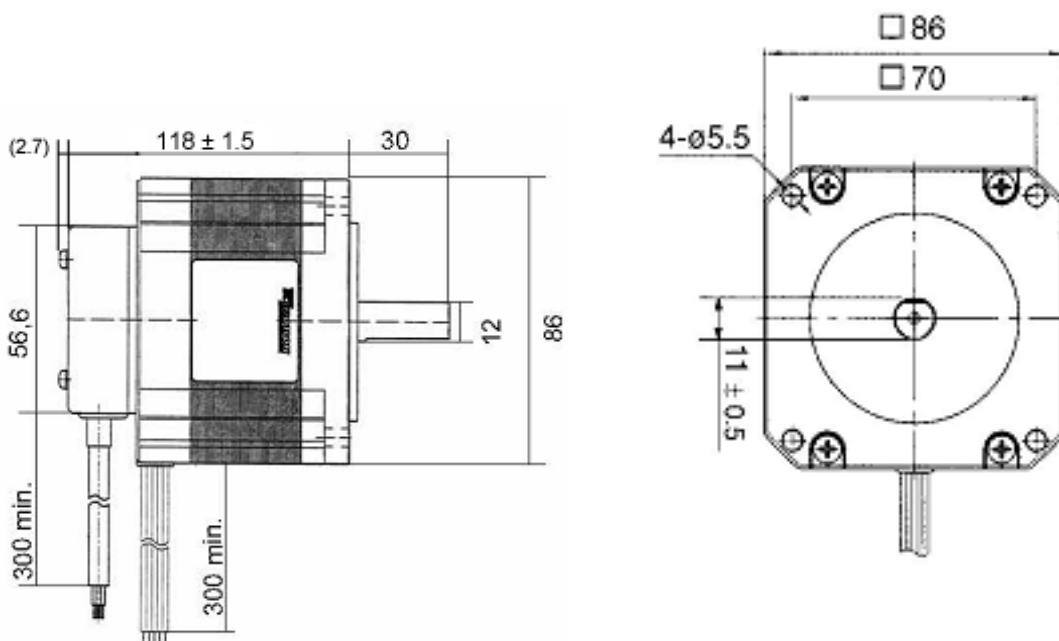

Optional sind für unsere Schrittmotoren Planetengetriebe erhältlich.

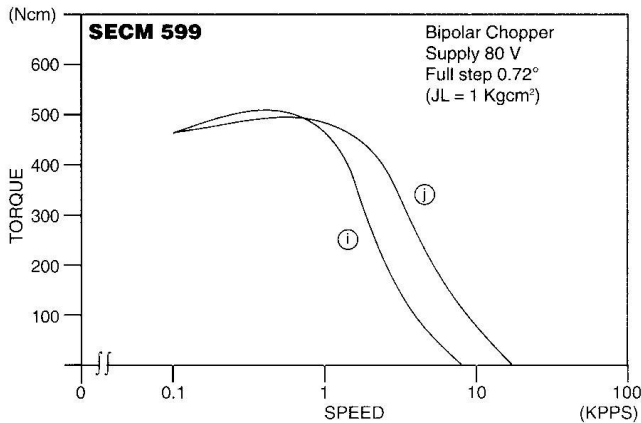

## Schrittmotoranschluss

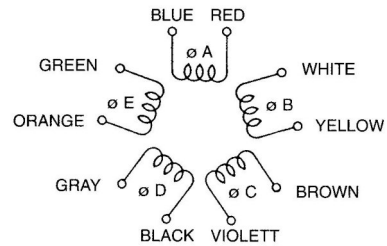

## Encoder Performance

Operating Temp.range : 0°C – 85°C  
 Supply : DC 5V ± 5% , 100mA max  
 Resolution : 500 Counts / Turn  
 Frequency Response : 100K Hz max.  
 A phase difference : 1/4 P ± 1/8 P  
 Code : Incremental A.B (2Ch.)

Output Signal : when output is high : DC 2.4V min  
 Output Signal : when output is low : DC 0.4V max  
 Sinking & Output Current : typical ± 20mA max  
 Rise & Fall Times : 1 µsec max  
 Moment of inertia : 5 g·cm<sup>2</sup> max Encoder only  
 Output Circuit : Line Driver AM26C3IIDB

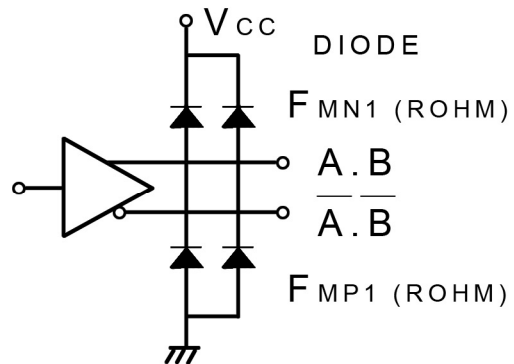
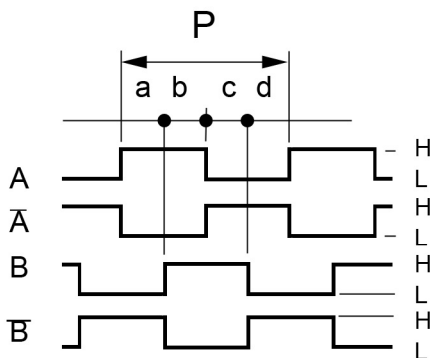

CW Rotation viewed from mounting end. Encoder signal A and B position is "H" at Motor 4Phase on.

## Color of Leadwires and Funktion :

DC 5V = red      A phase = brown      A-bar phase = orange  
 GND = blue      B phase = yellow      B-bar phase = gray

(Old-Version)

A phase = brown      A-bar phase = orange  
 B phase = yellow      B-bar phase = white  
 DC 5V = red      GND = black