

# BLACK FOREST LINK

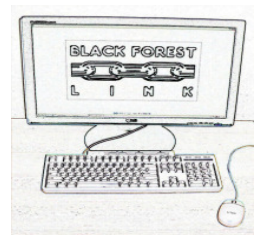
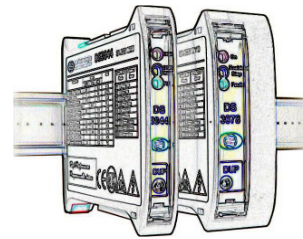
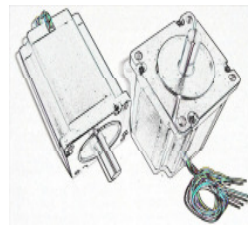

COMPONENTS – CONTROL SYSTEMS – APPLICATIONS

## VPC – VALVE AND PUMP CONTROLLER

“A compact and cost efficient motion controller for valve and pump control applications ...”

- 24 ... 90V<sub>DC</sub> motor supply
- 4 ... 10A<sub>RMS</sub> motor phase current
- 3 ... 30V wide range signal inputs
- Very compact dimensions:  
H:101mm D:119mm W:35mm
- Mounts on standard DIN rail
- 0 ... 10 V analog signal control  
Valve: Valve position  
Pump: Flow volume / time
- Encoder index pulse / reference signal input for automatic calibration after power on
- Monitoring output for valve position or pump speed
- Automatic motor current reduction at standstill to reduce heat loss of motor and drive
- Multiple safety functions:
  - Short circuit (over current)
  - Low supply voltage
  - Over temperature
  - Phase interruption detection
- Removable terminal blocks
- 3 diagnostic LEDs
- Customized versions available
- Powerful 2 phase stepper line



... featuring industrial quality motion controller/drive type LAM DS3078 with on-board application software VPC-xxx ...

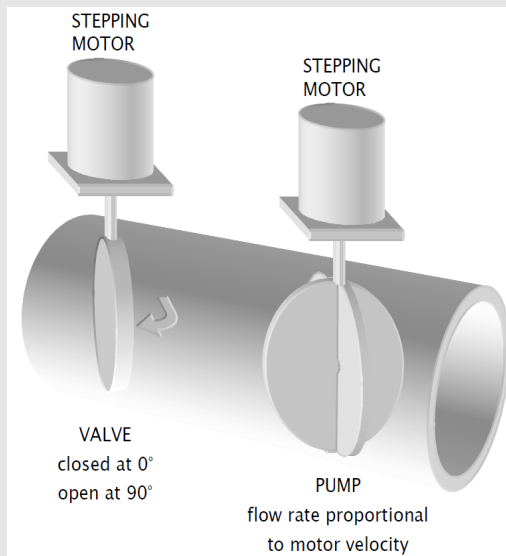

... to control valve positions an flow volumes of (dosage) pumps”

BLACK FOREST LINK..

... combines industrial high performance stepping motor drive and control systems with pre-engineered functionality for a variety of demanding applications...

...systems offer user friendly solutions for a variety of industries:

- Packaging
- Printing
- Labeling
- Automotive
- Food
- Medical
- Pharmaceutical
- ...

1 YEAR WARRANTY on standard products...

Please visit us at.. [www.blackfoli.com](http://www.blackfoli.com)

VPC-US0.1

## VPC-100 APPLICATION EXAMPLE: VALVE POSITION CONTROL

### Stepping Motor Interface

Low impedance and high current 2 phase stepper motor connection Positive movement means CW rotation looking towards motor shaft

Need to invert motor direction?  
Simply swap phase wires A and A/

### Analog signal interface for valve position set value

±10V Analog Signal  
GND Analog Signal

#### Attention:

- Use only shielded signal cable
- Keep signal cable length as short as possible
- Run cable separated from other cables (especially motor and power cables)

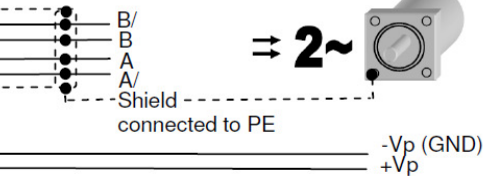
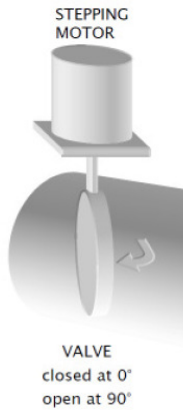

Optional Analog Output

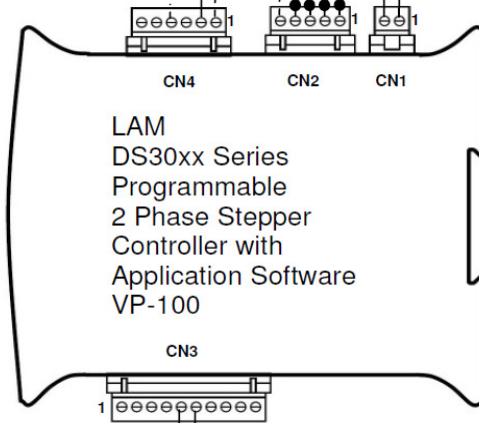

CN1 - Signals set-up	
Contact n.	Description
1	+Vp, positive DC supply voltage
2	-Vp (GND), negative DC supply voltage

CN2 - Signals set-up	
Contact n.	Description
1	FA-, negative output phase A
2	FA+, positive output phase A
3	FB+, positive output phase B
4	FB-, negative output phase B
5	SHIELD (internally connected with a GND)

CN3 - Signals	
Contact N.	Description
1	DI0+ DigitalInput(0), positive 0 digital input
2	DI0- DigitalInput(0), negative 0 digital input
3	DI1+ DigitalInput(1), positive 1 digital input
4	DI1- DigitalInput(1), negative 1 digital input
5	DI2+ DigitalInput(2), positive 2 digital input
6	DI2- DigitalInput(2), negative 2 digital input
7	DI3+ DigitalInput(3), positive 3 digital input
8	DI3- DigitalInput(3), negative 3 digital input
9	DO0+ DigitalOutput(0), positive 0 digital output
10	DO0- DigitalOutput(0), negative 0 digital output

CN4 - Signals	
Contact N.	Description
1	GND, analog signals ground (internally connected with power ground)
2	A10, 0 analog input
3	A10, 1 analog input
4	A00, 0 analog output
5	DO1+ DigitalOutput(1), positive 1 digital output
6	DO1- DigitalOutput(1), negative 1 digital output

### Calibration signal interface

Motor encoder with index pulse signal for automatic valve calibration after power on

